







# Introduction of an automatic and open-source radio-tracking system for small animals

Jannis Gottwald<sup>1</sup>  | Ralf Zeidler<sup>2</sup>  | Nicolas Friess<sup>1</sup>  | Marvin Ludwig<sup>1</sup>  |  
Christoph Reudenbach<sup>1</sup>  | Thomas Nauss<sup>1</sup> 

<sup>1</sup>Faculty of Geography, Philipps-University Marburg, Marburg, Germany

<sup>2</sup>Freies Institut für Datenanalyse – Dipl.-Phys. Ralf Zeidler, Freiburg, Germany

## Correspondence

Ralf Zeidler

Email: ralf.zeidler@radio-tracking.eu

## Funding information

Ministry of the Environment, Climate Protection and the Energy Sector Baden-Württemberg, Germany; Hessen State Ministry for Higher Education, Research and the Arts, Germany

Handling Editor: Chris Sutherland

## Abstract

1. Movement ecology of small wild animals is often reliant on radio-tracking methods due to the size and weight restrictions of available transmitters. In manual radio telemetry, large errors in spatial position and infrequent relocations prevent the effective analysis of small-scale movement patterns and dynamic aspects of habitat selection. Automatic radio-tracking systems present a potential solution for overcoming these drawbacks. However, existing systems use customized electronics and commercial software or exclusively record presence/absence data instead of triangulating the position of tagged individuals.
2. We present a low-cost automatic radio-tracking system built from consumer electronic devices that can locate the position of radio transmitters under field conditions. We provide information on the hardware components, describe mobile and stationary set-up options, and offer open-source software solutions.
3. We describe the workflow from hardware setup and antenna calibration, to recording and processing the data and present a proof of concept for forest-dwelling bats using a mixed forest as study area. With an average bearing error of 6.8° and a linear error of 21 m within a distance ranging from 65 m to 190 m, the accuracy of our system exceeds that of both traditional methods as well as manual telemetry.
4. This affordable and easy-to-use automatic radio-tracking system complements existing tools in movement ecology research by combining the advantages of lightweight and cost-efficient radio telemetry with an automatic tracking set-up.

## KEYWORDS

automatic radio-tracking, Marburg Open Forest, movement ecology, open-source, radio-tracking, telemetry, triangulation

## 1 | INTRODUCTION

The analysis of animal movements based on tracking data enables ecologists to investigate questions related to habitat and resource utilization (Wyckoff, Sawyer, Albeke, Garman, & Kauffman, 2018), migration and dispersal (Cagnacci, Boitani, Powell, & Boyce, 2010;

Walton, Samelius, Odden, & Willebrand, 2018) or to build predictive models of animal behaviour (Browning et al., 2018). Recent improvements in tracking technology have increased the number of locations recorded per animal from a few dozen by manual radio telemetry to millions of movement steps from GPS tags and satellite telemetry, leading Kays, Crofoot, Jetz, & Wikelski (2015) to proclaim

This is an open access article under the terms of the Creative Commons Attribution License, which permits use, distribution and reproduction in any medium, provided the original work is properly cited.

© 2019 The Authors. *Methods in Ecology and Evolution* published by John Wiley & Sons Ltd on behalf of British Ecological Society

a new golden age of animal tracking. To complement this more finely resolved movement data, researchers have also developed a variety of sophisticated analytical techniques such as path segmentation analysis, step-selection functions and autocorrelated kernel methods (Fleming et al., 2015; Seidel, Dougherty, Carlson, & Getz, 2018).

Despite numerous advantages, both GPS tracking and satellite telemetry are still limited in their application to practical conservation and ecological research. The cost of tags notwithstanding, size and weight have limited their deployment in the past. New developments have successfully reduced the weight of such tags to ~1 g (e.g. PinPoint GPS tags, Lotek Wireless, Newmarket, CA). Nevertheless, battery lifetime and recording frequency are inversely related to weight, so the tags either record with low frequency or have short battery lifetimes (e.g. 5 nights for a 4.2 g GPS tag with a 30-s GPS-fixed schedule; Roeleke, Teige, Hoffmeister, Klingler, & Voigt, 2016). Lightweight GPS tags also need to be retrieved to access the data (Hallworth & Marra, 2015), which either directly or indirectly increases most studies' expenditures in the form of lost material or data (Smith, Hart, Mazzotti, Basille, & Romagosa, 2018; Tomkiewicz, Fuller, Kie, & Bates, 2010). These limitations aside, such tags are also too heavy for species weighing less than 20 g, as their weight should not exceed 5% of the individual's body mass to which it is attached (Brooks, Bonyongo,

& Harris, 2008). This leaves radio tags, with weights as low as 0.2 g, as the single option for 50% of European passerines (Bauer, 2012) and 80% of European bats (Dietz, Nill, & Helversen, 2016).

Manual radio telemetry has disadvantages including labour intensity, low temporal and spatial resolution (Montgomery, Roloff, Ver Hoef, & Millspaugh, 2010; Thomas, Holland, & Minot, 2011), infrequent and irregularly timed locations (Alexander & Maritz, 2015), small sample sizes (usually one frequency at a time; (Kays et al., 2011)) and areal restrictions due to safety concerns for field workers (Smith et al., 2018). The quality of the resulting data also precludes any advanced analytical techniques created for fine-scale tracking data. Several working groups have designed automatic telemetry systems to overcome these drawbacks (Kays et al., 2011; Řeřucha et al., 2015; Weiser et al., 2016). Regardless of equipment, the key feature of modern automatic telemetry systems is a continuous signal record sent by radio tags using a stationary automatic receiver and a combination of either omnidirectional or directional Yagi-Uda antennae. The former can detect presence and absence, while the latter can detect the timing and direction of movement (Crysler, Ronconi, & Taylor, 2016; Falconer, Mitchell, Taylor, & Tozer, 2016). Existing systems use customized electronic devices with proprietary software (Kays et al., 2011; Weiser et al., 2016)

### BOX 1 Hardware overview

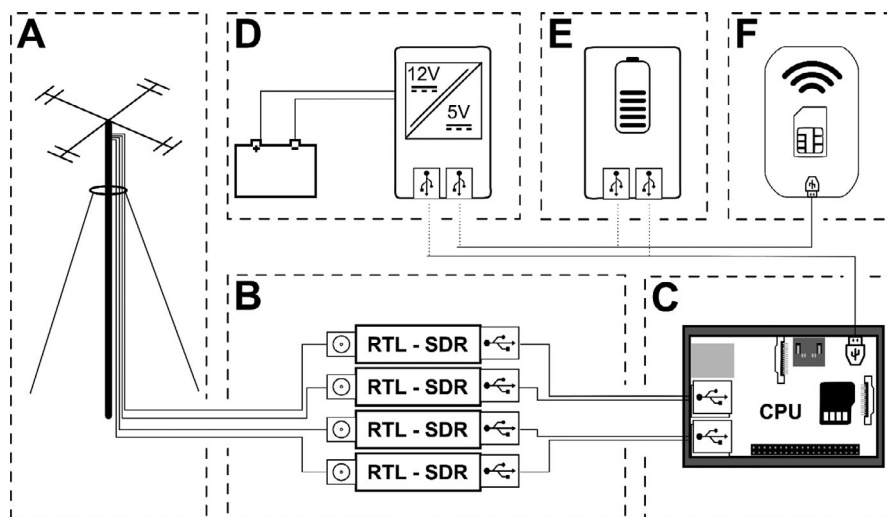

- A Station with four antennae positioned in the cardinal directions and tuned to the regional frequency for wildlife telemetry (around 150.100 MHz in Germany)
- B One RTL-SDR dongle per antenna (e.g. Nooelec NESDR SMart SDR, Nooelec, NY, USA) with a frequency range of 25–1,700 MHz and a maximal sample rate of 2 MHz (quadrature sampling)
- C Raspberry Pi 3B single-board computer (Farnell elements14, Leeds, UK) with the Raspbian operating system with a Docker-based architecture
- D High-capacity power supply with voltage regulation to work with the single-board computer, recommended for longer deployment times. Battery time can be further increased through solar panels and a solar charge regulator.
- E Power bank (20 Ah at 3.6 V), able to supply a station for ~8 hr, recommended for mobile setups
- F Mobile WiFi hotspot (Huawei E5330, Shenzhen, China), enables remote access within reach of the station's Raspberry Pi

or monitor presence and absence in large-scale movement studies, but cannot triangulate the position of a tagged individual (Taylor et al., 2017). Here, we describe an automatic radio-tracking system for locating individuals Zeidler, R. (2017) that has a high temporal and spatial resolution and works with inexpensive consumer electronics, flexible antenna designs and user-friendly, open-source software. In addition to a field test of system accuracy, we present a proof of concept based on forest-dwelling bats that illustrates the general use of the system under field conditions.

## 2 | SYSTEM COMPONENTS AND METHODS

### 2.1 | Core system

The low-cost, automatic radio-tracking system (Box 1, A, B, C) consists of three basic elements: (a) a receiver chip, (b) antennae and (c) a single-board computer (e.g. Raspberry Pi). Common DVB-T television receivers with RTL2832U chips process the radio signal (e.g. Nooelec NESDR SMArt SDR, NooElec, NY USA). Inexpensive software-defined radios (RTL-SDRs, Laufer, 2015) allow multiple radio signals to be simultaneously recorded. The RTL-SDRs connect the single-board computer with the Yagi-Uda antennae.

To calculate the source direction of incoming signals, the antenna pole at a given station requires an array of at least three directional antennae (and an equal number of receivers) together with information about their orientation. The number of receivers that one computer can monitor depends on the number of available USB ports.

At least two antenna setups with known coordinates must be available and within the range of the radio source to triangulate the tag's position. Each station should be connected to the Internet to guarantee synchronized system times with e.g. a mobile Wi-Fi hotspot carrying a SIM card (Box 1, F). The Network Time Protocol synchronizes the station times when they are first operational and approximately every 5 min thereafter.

The stations are operated using custom software. Operational hardware settings on the receiving units can be done by remote

access in a user-friendly web-interface. This includes the setting of the monitored frequency band, activation of receivers as well as settings to reduce the recording of interference. Once the receivers are activated, they digitize incoming signals. An algorithm based on liquidSDR (Gaeddert, 2016) automatically detects peaks in the radio signals along with timestamps, the frequency relative to a user-defined mid-frequency (Hz), signal bandwidth (Hz), duration of the signal (s) and signal strength (dB; For additional information see [www.radio-tracking.eu](http://www.radio-tracking.eu)).

### 2.2 | Transmitter specifications

The system supports any type of radio tag common in wildlife radio telemetry. Individual tags are identified by their specific frequency. The number of tags that can be simultaneously monitored depends on the tag features and the possible width of the frequency band, as constrained by the CPU performance (e.g. 250 kHz for the Raspberry Pi 3 Model B, 1 MHz for the Model A+). With highly stable tag frequencies, tags can have frequencies as small as 1 kHz apart. Pulse timing is irrelevant for signal detection, which enables tags that transfer additional information (e.g. body temperature by varying time intervals between pulses) to be deployed. Tags are attached to the animal's skin, fur or feathers using skin glue that dissolves after a certain time. Alternatively, tags can be attached by e.g. harnesses and collars. Depending on the size of the tag, they can be operational between a few days and several months.

### 2.3 | Principle of bearing calculation and triangulation

Signal amplification of a directional antenna depends on the angle of the incoming electromagnetic wave. The relation between the gain of a directional antenna and the angle of arrival can be approximated using a cosine function (Figure 1, Equation 1, Rabinovich & Alexandrov, 2013), where  $g(\omega)$  describes the gain or loss relative to the angle  $\omega$  in degrees compared to the gain of  $\omega = 0^\circ$ .

$$g(\omega) = \frac{\cos\left(\frac{\pi}{90} \times \omega\right)}{2} + \frac{1}{2} \quad (1)$$

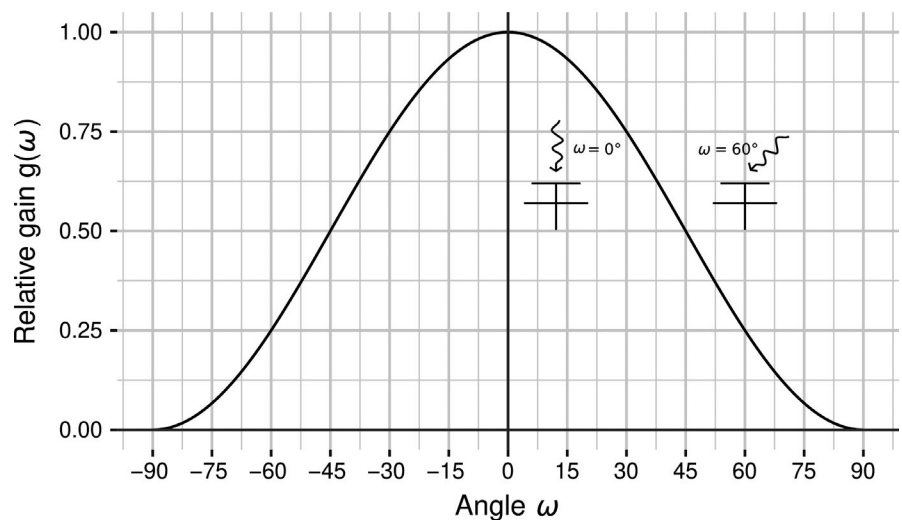
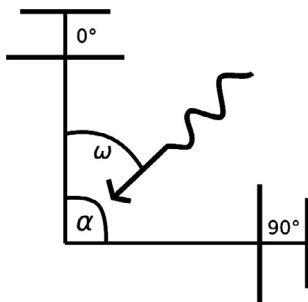

**FIGURE 1** Radiation pattern of directional antennae

In comparing two antennae of the same design, the absolute gain in dB can be ignored because the values will be subtracted. Assuming that the propagation path of the incoming electromagnetic wave to the antenna is the same for both antennae (see also calibration), the direction of arrival ( $\omega$ ) of the transmitter signal is calculated by comparing the relative gains of two neighboring antennae (Equations 2, 3, 4) with  $\alpha$  describing the angle between the antennae (Figure 2).

$$\Delta g(\omega, \alpha) = \frac{\cos\left(\frac{\pi}{90} \times \omega\right)}{2} - \frac{\cos\left(\frac{\pi}{90} \times (\omega - \alpha)\right)}{2} \quad (2)$$

$$\Delta g(\omega) = \cos\left(\frac{\pi}{90} \times \omega\right) \text{ with } \alpha = 90^\circ \quad (3)$$



**FIGURE 2** Incoming signal (wavy line), angle  $\omega$  in degrees compared to  $\omega = 0^\circ$ , angle between antennae  $\alpha$

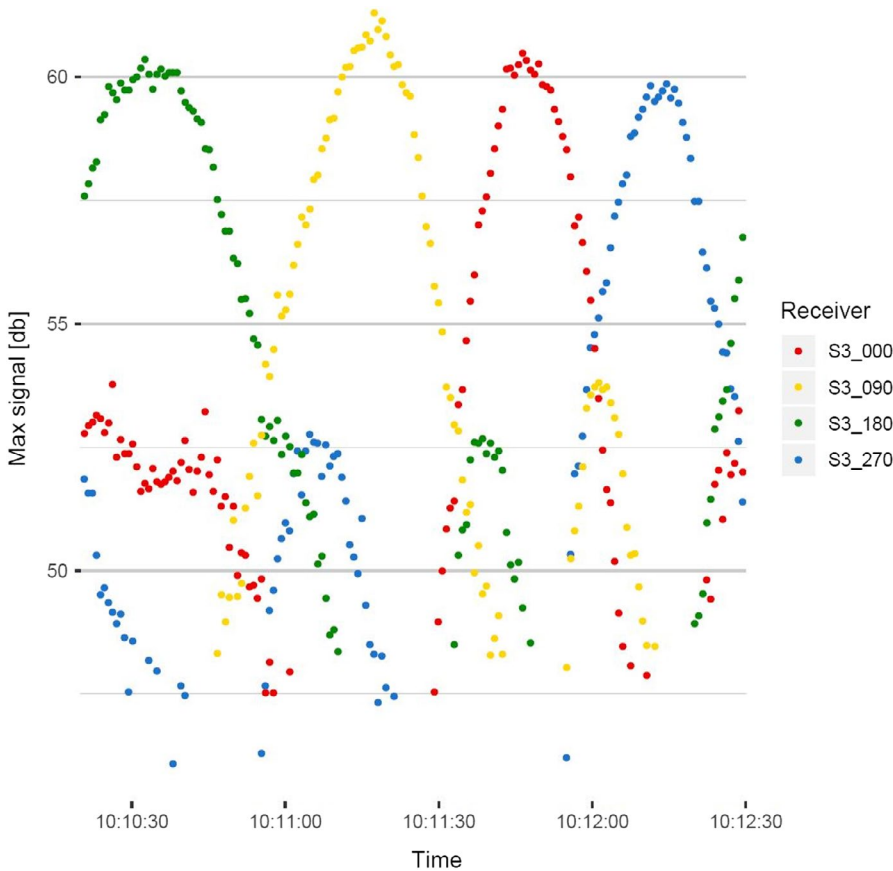

$$\omega = \frac{\pi}{90} \times \arccos(\Delta g) \text{ with } \alpha = 90^\circ \quad (4)$$

To calculate  $\Delta g$  in Equation 4, the difference in signal strength between the two antennae ( $s_l$  and  $s_r$ ) is normalized with the maximum signal strength difference  $\Delta m$  (Equation 5).

$$\Delta g = \frac{(s_l - s_r)}{\Delta m} \quad (5)$$

This can be derived by either simulating the gain pattern of the antennae or a simple field experiment, in which the signal loss of the antenna pointing directly at the tag ( $0^\circ$ ) is compared to the signal loss of an antenna angled  $90^\circ$  relative to the tag.

Therefore, the direction of arrival is a function of the normalized signal loss between the antennae and the angle between those antennae:

$$\omega(\Delta g, \alpha) = \left(1 - \cos\left(\frac{-\alpha \times \pi}{90}\right)\right) \times \left(\frac{1}{\alpha} \Delta g + \frac{1}{2}\right) \quad (6)$$

The tag's position is approximated by finding the point of intersection of two lines produced by bearing calculations at two separate stations. If more than two stations simultaneously receive the signal, the centroid of the resulting polygon is calculated.

### 2.4 | Calibration

Recorded signals may differ in strength due to varying sensitivities of the components (e.g. antennae, cables, plugs, receivers). Since the

**FIGURE 3** Calibration curves of four HB9CV antennae arranged in an array with  $90^\circ$  difference between neighbouring antennae (Station S-S3). A radio tag was placed c. 115 m away and the array was slowly turned on its vertical axis

bearing calculation relies on an equal net gain at each receiving arm, each arm must be calibrated. Calibration curves can be produced by mounting a transmitter at a fixed distance to the station and rotating the station around its vertical axis (Figure 3). Calculating the difference between each antenna's local maximum and the strongest local maximum signal returns a correction value for each receiving arm. Adding the correction value to the recorded signal strength adjusts every antenna to the same maximum signal strength.

## 2.5 | Data processing

Different processing workflows were tested to identify relevant settings and boundary conditions for obtaining optimal tracking results.

The bearing calculation requires that each receiving arm reliably record the signal. An individual antenna may drop a signal when the angle of the incoming electromagnetic wave strongly deviates from the angle of possible maximum gain ( $\omega = 0^\circ$ ). Furthermore, very small or large intersection angles between bearings from two stations may produce erroneous or no triangulations, if bearings run parallel.

We tested the effect of available antennae on the accuracy of bearing calculations. The error of each bearing based on two, three or four receiving antennae was assessed by the difference in the calculated bearing and the angle between a station and the respective test position.

To assess the influence of intersection angles between bearings, we triangulated points and iteratively increased and decreased the allowed minimum and maximum intersection angle by  $10^\circ$ ,

respectively. For each set of triangulation points, we calculated the position error, which is the mean distance between the expected and measured positions.

Data were processed using R version 3.6.0 (R Core Team, 2019). The functions are publicly available as an R Shiny analysis tool ([https://github.com/radiotrackingeu/logger\\_app](https://github.com/radiotrackingeu/logger_app)) or an R package (<https://github.com/radiotrackingeu/radiotrackingeu>).

## 2.6 | Accuracy study on an empty field

In January 2019, we installed and tested this system on a bare field free of vegetation to assess the its potential accuracy and evaluate the data processing algorithm. The test setup comprised three stations, each equipped with four directional antennae (HB9CV, Telemetrie-Service Dessau) connected to RTL-SDR receivers (Nooelec NESDR SMARt SDR, NooElec). The system was mounted on 2.5 m tripods that were installed in an isosceles triangle formation with 200 m side length. The stations were calibrated against a transmitter at a fixed distance of 115 m. After calibration, a sighting compass was used to position each station's antennae in the cardinal directions. A regular, 50 m-wide test grid was constructed between the stations and a 400  $\mu$ W VHF radio-tag with a frequency of 150.203 kHz and a pulse interval of 0.7 s mounted on a 2 m pole was placed at each intersection of the test grid (Figure 4). The intersections and the stations were localized with a differential GPS. The distance of the radio-tracking stations to the test positions ranged from 65 m to 190 m.

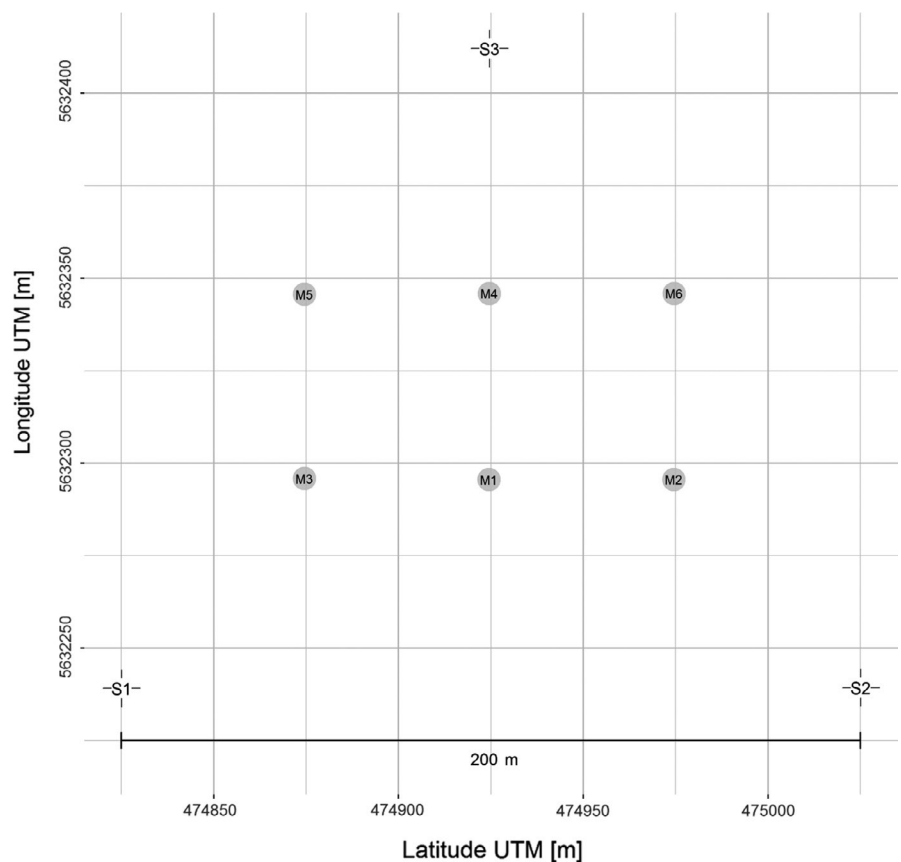

**FIGURE 4** Testing scheme. Radio-tracking stations (S1–S3) were placed in an isosceles triangle and a radio tag was placed on each reference position for 2 min (M1–M6)

## 2.7 | Usability study of forest-dwelling bats in a mixed forest area

Results from an ongoing study that is part of the LOEWE priority program Nature 4.0 – Sensing Biodiversity are briefly presented and discussed to demonstrate the system's capability under field conditions. In 2019, 15 tracking stations were installed in the Marburg Open Forest, the open research and education forest of the University of Marburg, to track bats and songbirds over each breeding season until 2022. Each station is equipped with an array of four HB9CV antennae mounted on 9 m aluminium poles. The stations record movement and body temperature data of tagged bats, which belong to one of four forest-dwelling species (*Nyctalus leisleri*, *Myotis daubentonii*, *Myotis bechsteinii*, *Barbastella barbastellus*). The temperature sensitive tags (V3, Telemetrie-Service Dessau, 0.35 g) vary the time interval between consecutive signals based on the individual's skin temperature.

Exemplary results of bat activity are shown for 26 June 2019. The optimal settings as identified in the accuracy test study were used to triangulate individuals' positions. In order to handle and tag the bats, a special license was granted by the Nature Conservancy Department of Central Hessen ('Obere Naturschutzbehörde Mittelhessen, Regierungspräsidium Gießen', v54-19c 2015 h01).

**TABLE 1** Correction values in dB based on calibration curves obtained in the field

Station	Correction [dB] 0°	Correction [dB] 90°	Correction [dB] 180°	Correction [dB] 270°
S1	2.2	1.7	0	0.07
S2	0.26	1.7	0	2.9
S3	0.8	0	0.9	0.98

Tags were attached to the skin between the scapula with skin adhesive (Manfred Sauer GmbH, Lobbach Germany) and the weight of the attached tags was always <5% of the tagged individual's body mass.

## 3 | RESULTS

### 3.1 | Results of the accuracy study

Correction values obtained from local maxima in the calibration curves ranged between 0.07 dB and 2.9 dB with the lowest and highest deviations in maximum received signal strength for stations S3 and S2, respectively (Table 1). Thus, calibration had the strongest effect on S2, improving the bearing error from a median of 11.6° to 5.4° (Figure 5). Calibration improved the median bearing accuracy by 2° across all stations.

Bearings calculated based on signals recorded by two antennae deviated from the real angle by 14.9° (median). Bearing error was reduced to 6.8° when more than two antennae received a signal (Figure 6).

The position error decreased as the minimum and maximum permissible intersection angles converged towards 90° (Figure 7). Minimum and maximum angles of 40° and 140°, respectively, substantially improved results as well as sharply reducing the number of triangulated points. Placing additional limits on the intersection angle steadily reduced the available data.

Positions were triangulated with calibrated signal strengths and a minimum of three available antennae. Since a substantial number of locations were lost due to restrictions to the intersection angle, we triangulated positions with all intersection angles and with intersection angles restricted to 40–140°. Including all possible intersection angles in the triangulation process results in 673 locations and a mean positioning error of 25 m. The triangulated points scatter in string-shaped patterns

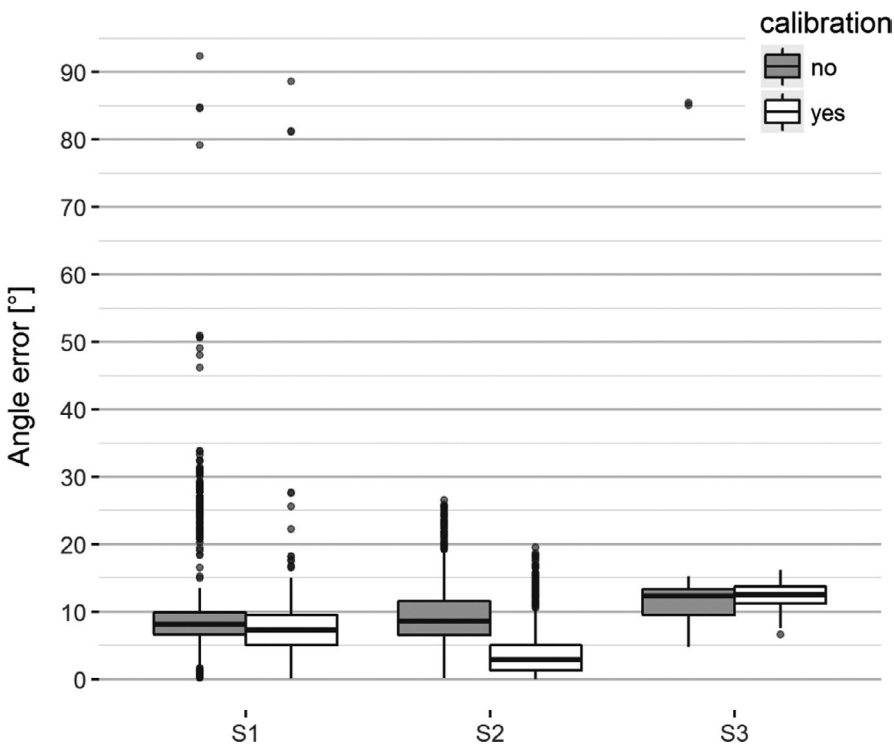

**FIGURE 5** Difference in angle error before and after calibration. Calibration substantially reduces the number of points with a high bearing error (outliers in the boxplot)

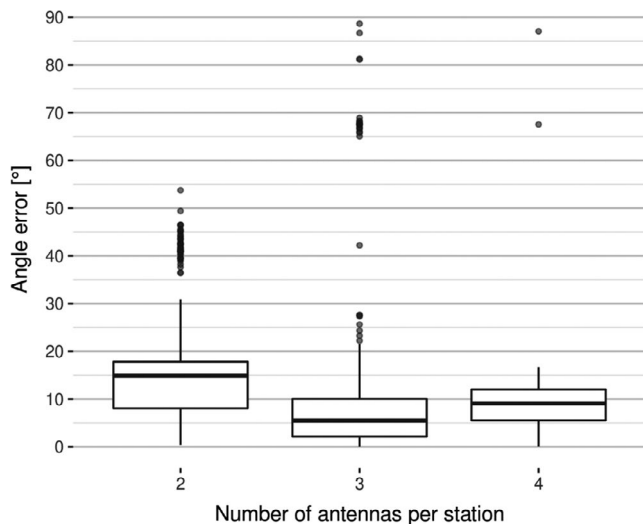

**FIGURE 6** Absolute deviation of the bearings from the real angle depending on the number of antennae available. The mean absolute error is  $7^\circ$  with a standard deviation of  $6.2^\circ$

around the reference positions (Figure 8). Restricting the intersection angles to a minimum of  $40^\circ$  and a maximum of  $140^\circ$  reduces this error to 21 m. However, this results in a substantial loss of triangulated points (292; Figure 8) with no points for position M5 (Figure 8).

### 3.2 | Results of the forest usability study

Tracking the movement of *M. bechsteinii* reveals different areas of activity throughout the night (Figure 9, left). During 5-min intervals that night (Figure 9, right), 301 positions were recorded within an activity area of approximately  $50 \text{ m}^2$ .

Body temperature patterns of four different bat species are shown for nocturnal activity and resting in the day roost (Figure 10).

For the *B. barbastellus* as well as for the *M. daubentonii*, a clear drop of the body temperature of approximately  $7^\circ\text{C}$  was recorded shortly before and after sunrise, respectively.

## 4 | DISCUSSION

The automatic radio-tracking system presented in this paper incorporates the advantages of lightweight and cost-efficient radio telemetry into a continuous tracking setup. This enhances the number of triangulated positions without manual telemetry and allows analytical techniques previously reserved for fine-scale GPS tracks to be used. These techniques enable researchers to glean important information about different behavioural states of an individual over large trajectories. The exemplary 5-min tracking interval, for example, shows a low displacement in spatial units in relation to the time spent within the area in question, which may be interpreted as an intensive area-restricted search and, thus, foraging behaviour (Knell & Codling, 2012).

Overall, the accuracy of the radio-tracking system from the field test compares well to reported manual bearing errors of experienced field workers (Bartolommei, Francucci, & Pezzo, 2013). However, this strongly depends on the data processing techniques used. Antenna calibration reduces the bearing error, confirming both the underlying theoretical assumption and the need for calibration to obtain reasonable results. For more precise results, all bearings calculated based on fewer than three available antennae should be excluded from triangulated results. Reducing the intersection angle improves results, yet also reduces the size of the dataset.

Since incorrect positioning in our field test appears systematic, errors can be more accurately considered than in manual telemetry and may be further reduced by, for example, field experiments that are able to capture this regularity.

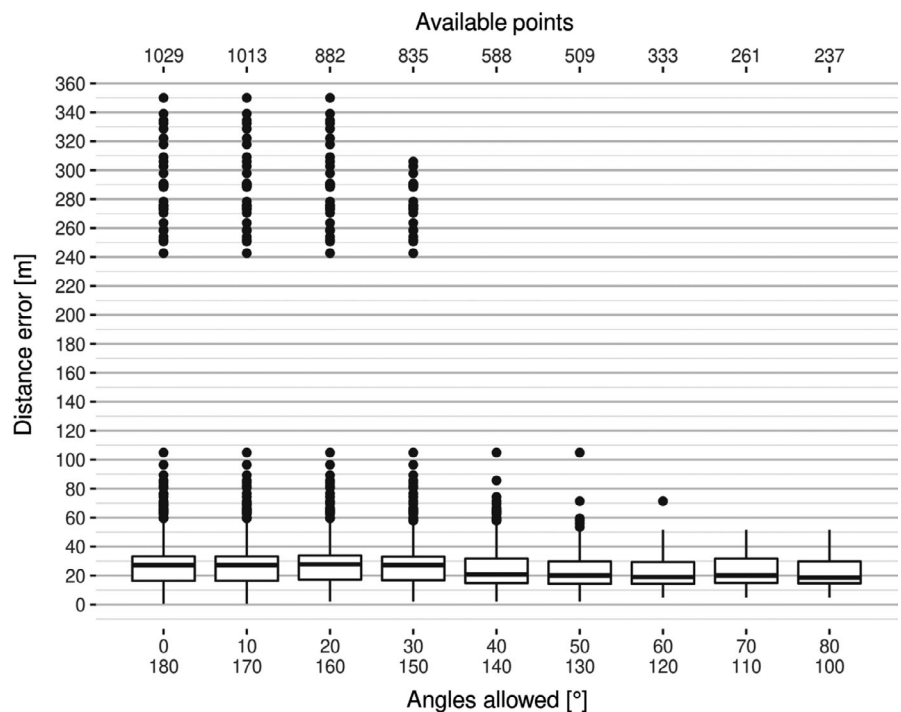

**FIGURE 7** Distance error and available locations depending on the allowed cutting angle

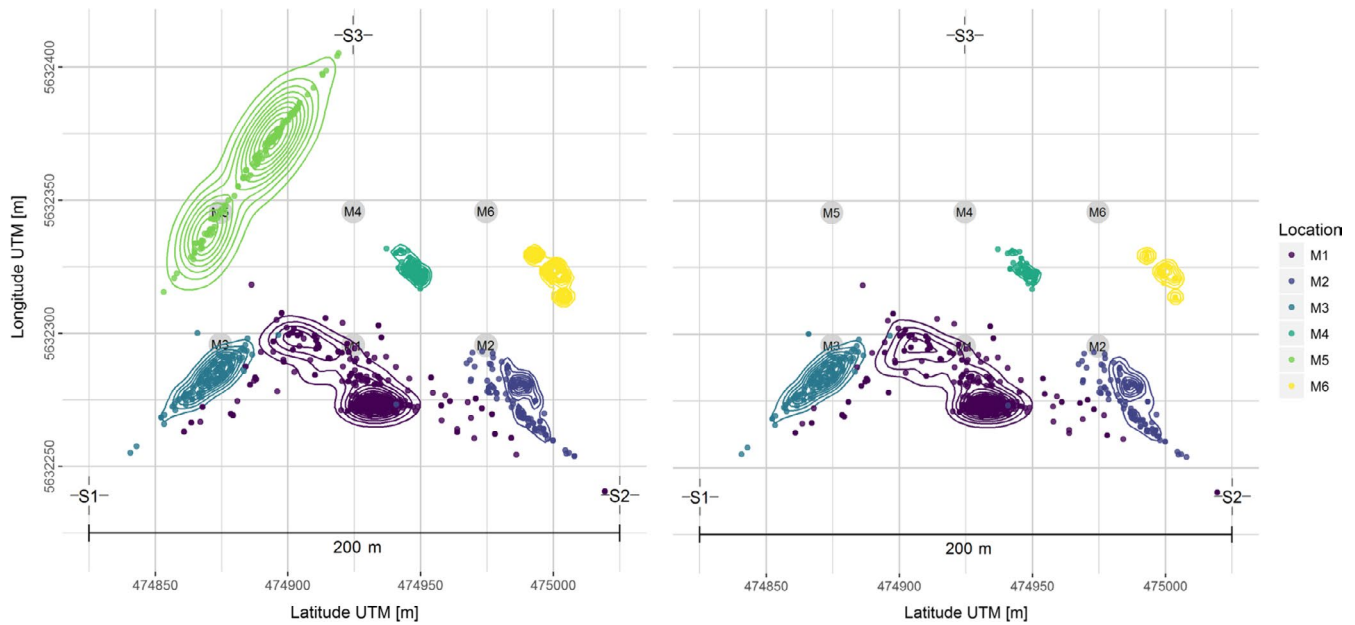

**FIGURE 8** Localization points with all cutting angles between two antennae allowed (left) and with cutting angles restricted to 40–140° (right). Isolines represent point density increasing from the outside to the inside

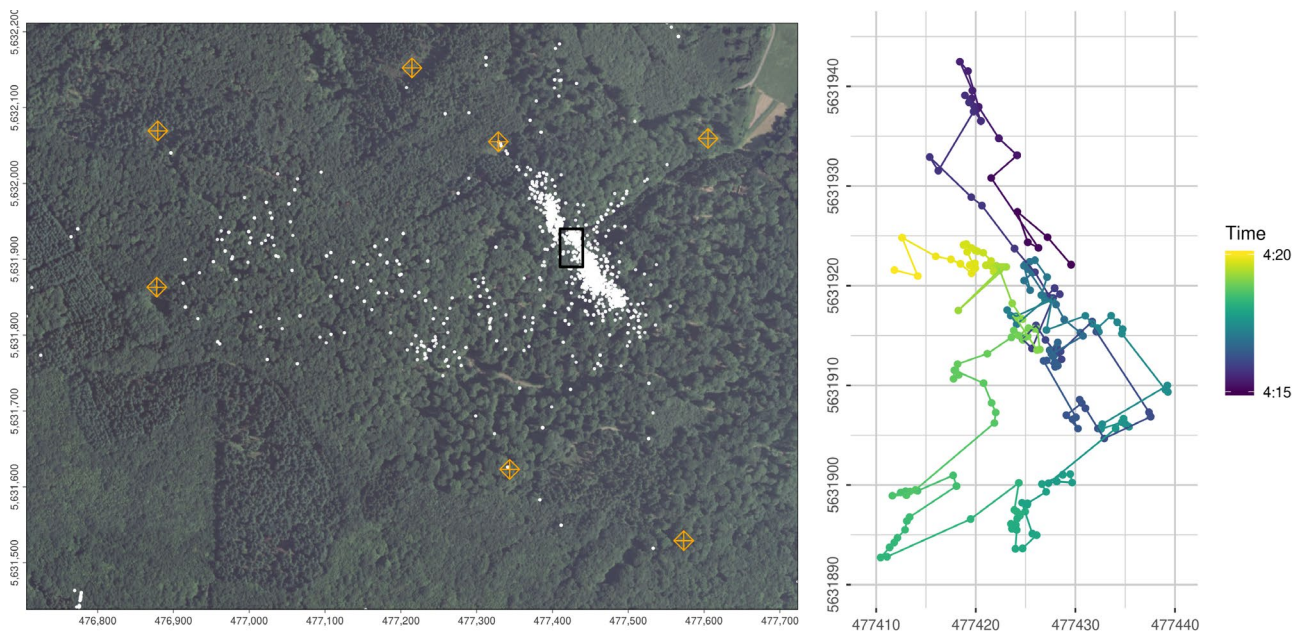

**FIGURE 9** Tracking data of a Bechstein's bat recorded on the night of 26 June 2019 (left). Yellow crosses indicate permanent radio-tracking stations. The bounding box (black box) highlights the area of 5 min of relocations shown in detail in the right part of the figure

The low-cost solution for automatic radio-tracking presented in this study enables researchers to apply automatic radio-tracking techniques in the field while the open-source hardware and software components allows for active participation in future development. As the principle of calculating bearing is based on physical properties shared by most directional antennae, these algorithms are suitable for triangulating positions with data gathered by other systems such as SensorGnome (<https://sensorgnome.org>). Further relevant features, such as recording tagged

individuals' body temperature have also been implemented and tested.

Continuously measuring animal positions and movement with a long-term antenna setup can greatly contribute to research into animal behaviour. The movement tracks it generates are comparable to those generated by satellite and GPS tracking techniques, even below the canopy in forested areas. This allows researchers to investigate questions related to small-scale habitat and resource utilization, choice of breeding sites or migration and dispersal events in organism groups



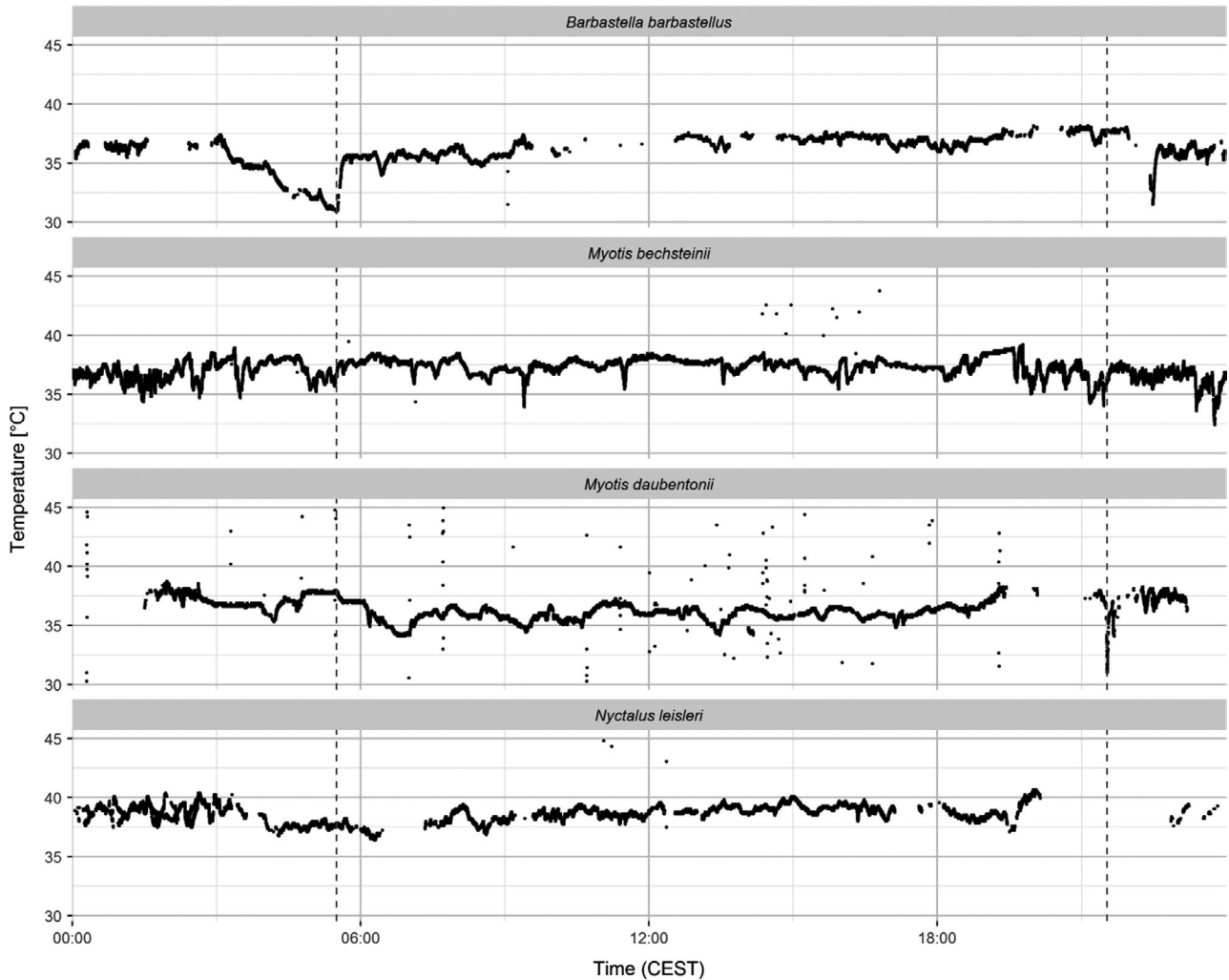

**FIGURE 10** 24-hr temperature curves of four different bat species

that movement ecologists cannot yet adequately study due to size restrictions. In this vein, this affordable and easy-to-use automatic radio-tracking system adds a powerful tool to movement ecology research.

## ACKNOWLEDGEMENTS

The first permanent setup of the system was implemented at Marburg Open Forest – the open research and education forest of Marburg University. The research is funded by the Hessen State Ministry for Higher Education, Research and the Arts, Germany, as part of the LOEWE priority project Nature 4.0 – Sensing Biodiversity. Radio-tracking.eu is the outcome of a feasibility study financially supported by the Ministry of the Environment, Climate Protection and the Energy Sector Baden-Württemberg, Germany.

## AUTHORS' CONTRIBUTIONS

R.Z. invented the system and developed the algorithms for bearing calculation. J.G., C.R., M.L., N.F. and T.N. provided development support, especially in the development regarding dislocation corrections

and monitoring of body temperature. J.G. and M.L. collected the test data; bat foraging data were collected by J.G., M.L. and N.F. led the writing of the manuscript. All authors interpreted the data and contributed to the manuscript.

## DATA AVAILABILITY STATEMENT

Example data is provided online on Zenodo (Zenodo <https://doi.org/10.5281/zenodo.3381909> (Gottwald, 2019)) and can be processed using the R package “RADIOTRACKINGEU” (<https://github.com/radiotrackingeu/radiotrackingeu>, Zenodo <https://doi.org/10.5281/zenodo.3381316> (Zeidler, 2019)).

## ORCID

Jannis Gottwald  <https://orcid.org/0000-0001-7763-1415>

Ralf Zeidler  <https://orcid.org/0000-0002-3607-6512>

Nicolas Friess  <https://orcid.org/0000-0003-0517-3798>

Marvin Ludwig  <https://orcid.org/0000-0002-3010-018X>

Christoph Reudenbach  <https://orcid.org/0000-0002-7476-3663>

Thomas Nauss  <https://orcid.org/0000-0003-3422-0960>

## REFERENCES

- Alexander, G. J., & Maritz, B. (2015). Sampling interval affects the estimation of movement parameters in four species of African snakes: Sampling interval affects estimation of movement. *Journal of Zoology*, 297(4), 309–318. <https://doi.org/10.1111/jzo.12280>
- Bartolommei, P., Francucci, S., & Pezzo, F. (2013). Accuracy of conventional radio telemetry estimates: A practical procedure of measurement. *Hystrix, The Italian Journal of Mammalogy*, 23(2), 91–94. <https://doi.org/10.4404/hystrix-23.2-6376>
- Bauer, H.-G. (Ed.) (2012). *Das Kompendium der Vögel Mitteleuropas: Ein umfassendes Handbuch zu Biologie, Gefährdung und Schutz* (Einbändige Sonderausgabe der 2, vollst. überarb. Auflage 2005). Wiebelsheim: AULA-Verlag.
- Brooks, C., Bonyongo, C., & Harris, S. (2008). Effects of global positioning system collar weight on zebra behavior and location error. *Journal of Wildlife Management*, 72(2), 527–534. <https://doi.org/10.2193/2007-061>
- Browning, E., Bolton, M., Owen, E., Shoji, A., Guilford, T., & Freeman, R. (2018). Predicting animal behaviour using deep learning: GPS data alone accurately predict diving in seabirds. *Methods in Ecology and Evolution*, 9(3), 681–692. <https://doi.org/10.1111/2041-210X.12926>
- Cagnacci, F., Boitani, L., Powell, R. A., & Boyce, M. S. (2010). Animal ecology meets GPS-based radiotelemetry: A perfect storm of opportunities and challenges. *Philosophical Transactions of the Royal Society B: Biological Sciences*, 365(1550), 2157–2162. <https://doi.org/10.1098/rstb.2010.0107>
- Core Team, R. (2019). R: The R project for statistical computing. Retrieved from <https://www.r-project.org/> (accessed date 22 July 2019).
- Crysler, Z. J., Ronconi, R. A., & Taylor, P. D. (2016). Differential fall migratory routes of adult and juvenile Ipswich Sparrows (*Passerculus sandwichensis princeps*). *Movement Ecology*, 4(1), 1–8. <https://doi.org/10.1186/s40462-016-0067-8>
- Dietz, C., Nill, D., & von Helversen, O. (2016). *Handbuch der Fledermäuse – Europa und Nordwestafrika* (2nd ed.). Stuttgart: Kosmos.
- Falconer, C. M., Mitchell, G. W., Taylor, P. D., & Tozer, D. C. (2016). Prevalence of disjunct roosting in nesting bank swallows (*Riparia riparia*). *The Wilson Journal of Ornithology*, 128(2), 429–434. <https://doi.org/10.1676/1559-4491-128.2.429>
- Fleming, C. H., Fagan, W. F., Mueller, T., Olson, K. A., Leimgruber, P., & Calabrese, J. M. (2015). Rigorous home range estimation with movement data: A new autocorrelated kernel density estimator. *Ecology*, 96(5), 1182–1188. <https://doi.org/10.1890/14-2010.1>
- Gaeddert, J. D. (2016). Liquid-dsp (version 1.3.0). Retrieved from <http://liquidsdr.org/>.
- Gottwald, J. (2019). Example data from radio-tracking.eu project [Data set]. Zenodo. <https://doi.org/10.5281/zenodo.3381909>
- Hallworth, M. T., & Marra, P. P. (2015). Miniaturized GPS tags identify non-breeding territories of a small breeding migratory songbird. *Scientific Reports*, 5(1), 11069. <https://doi.org/10.1038/srep11069>
- Kays, R., Crofoot, M. C., Jetz, W., & Wikelski, M. (2015). Terrestrial animal tracking as an eye on life and planet. *Science*, 348(6240), aaa2478. <https://doi.org/10.1126/science.aaa2478>
- Kays, R., Tilak, S., Crofoot, M., Fountain, T., Obando, D., Ortega, A., ... Wikelski, M. (2011). Tracking animal location and activity with an automated radio telemetry system in a tropical rainforest. *The Computer Journal*, 54(12), 1931–1948. <https://doi.org/10.1093/comjnl/bxr072>
- Knell, A. S., & Codling, E. A. (2012). Classifying area-restricted search (ARS) using a partial sum approach. *Theoretical Ecology*, 5(3), 325–339. <https://doi.org/10.1007/s12080-011-0130-4>
- Lafer, C. (2015). *The hobbyist's guide to the RTL-SDR. Really cheap software defined radio: A guide to the RTL-SDR and cheap software defined radio by the authors of the RTL-SDR.com blog* (2, print ed.). S.I.: CreateSpace Independent Publishing Platform.
- Montgomery, R. A., Roloff, G. J., Ver Hoef, J. M., & Millsbaugh, J. J. (2010). Can we accurately characterize wildlife resource use when telemetry data are imprecise? *Journal of Wildlife Management*, 74(8), 1917–1925. <https://doi.org/10.2193/2010-019>
- Rabinovich, V., & Alexandrov, N. (2013). *Antenna arrays and automotive applications*. New York, NY: Springer, New York. <https://doi.org/10.1007/978-1-4614-1074-4>
- Řeřucha, Š., Bartonička, T., Jedlička, P., Čížek, M., Hlouša, O., Lučan, R., & Horáček, I. (2015). The BAARA (Biological Automated Radiotracking) system: A new approach in ecological field studies. *PLoS ONE*, 10(2), e0116785. <https://doi.org/10.1371/journal.pone.0116785>
- Roeleke, M., Teige, T., Hoffmeister, U., Klingler, F., & Voigt, C. C. (2016). Habitat use of bats in relation to wind turbines revealed by GPS tracking. *Scientific Reports*, 6, 28961. <https://doi.org/10.1038/srep28961>
- Seidel, D. P., Dougherty, E., Carlson, C., & Getz, W. M. (2018). Ecological metrics and methods for GPS movement data. *International Journal of Geographical Information Science*, 32(11), 2272–2293. <https://doi.org/10.1080/13658816.2018.1498097>
- Smith, B. J., Hart, K. M., Mazzotti, F. J., Basille, M., & Romagosa, C. M. (2018). Evaluating GPS biologging technology for studying spatial ecology of large constricting snakes. *Animal Biotelemetry*, 6(1), 1–13. <https://doi.org/10.1186/s40317-018-0145-3>
- Taylor, P. D., Crewe, T. L., Mackenzie, S. A., Lepage, D., Aubry, Y., Crysler, Z., ... Woodworth, B. K. (2017). The Motus Wildlife Tracking System: A collaborative research network to enhance the understanding of wildlife movement. *Avian Conservation and Ecology*, 12(1), 1–11. <https://doi.org/10.5751/ACE-00953-120108>
- Thomas, B., Holland, J. D., & Minot, E. O. (2011). Wildlife tracking technology options and cost considerations. *Wildlife Research*, 38(8), 653. <https://doi.org/10.1071/WR10211>
- Tomkiewicz, S. M., Fuller, M. R., Kie, J. G., & Bates, K. K. (2010). Global positioning system and associated technologies in animal behaviour and ecological research. *Philosophical Transactions of the Royal Society B: Biological Sciences*, 365(1550), 2163–2176. <https://doi.org/10.1098/rstb.2010.0090>
- Walton, Z., Samelius, G., Odden, M., & Willebrand, T. (2018). Long-distance dispersal in red foxes *Vulpes vulpes* revealed by GPS tracking. *European Journal of Wildlife Research*, 64(6), 64. <https://doi.org/10.1007/s10344-018-1223-9>
- Weiser, A. W., Orchan, Y., Nathan, R., Charter, M., Weiss, A. J., & Toledo, S. (2016). Characterizing the accuracy of a self-synchronized reverse-gps wildlife localization system. In 2016 15th ACM/IEEE International Conference on Information Processing in Sensor Networks (IPSN) (pp. 1–12). Vienna, Austria: IEEE. <https://doi.org/10.1109/IPSNS.2016.7460662>
- Wyckoff, T. B., Sawyer, H., Albeke, S. E., Garman, S. L., & Kauffman, M. J. (2018). Evaluating the influence of energy and residential development on the migratory behavior of mule deer. *Ecosphere*, 9(2), e02113. <https://doi.org/10.1002/ecs2.2113>
- Zeidler, R. (2017). Project – Radio-Tracking.eu. Retrieved from <https://radio-tracking.eu/> (accessed date 18 July 2019).
- Zeidler, R. (2019). radiotrackingeu/radiotrackingeu: Initial release (Version v1.0). Zenodo. <https://doi.org/10.5281/zenodo.3381316>

**How to cite this article:** Gottwald J, Zeidler R, Friess N, Ludwig M, Reudenbach C, Nauss T. Introduction of an automatic and open-source radio-tracking system for small animals. *Methods Ecol Evol*. 2019;10:2163–2172. <https://doi.org/10.1111/2041-210X.13294>